

# File systems

**Security and Privacy**  
**VSE Prag, 7 - 11.6.2010**

Institute for Information Processing and  
Microprocessor Technology (FIM)  
Johannes Kepler University Linz, Austria

E-Mail: [sonntag@fim.uni-linz.ac.at](mailto:sonntag@fim.uni-linz.ac.at)  
<http://www.fim.uni-linz.ac.at/staff/sonntag.htm>



- Physical disk layout
- The boot sequence
  - What changes on a disk during a boot?
- File systems in detail:
  - FAT, FAT32
  - NTFS
  - EXT3

# Physical structure of a harddisk

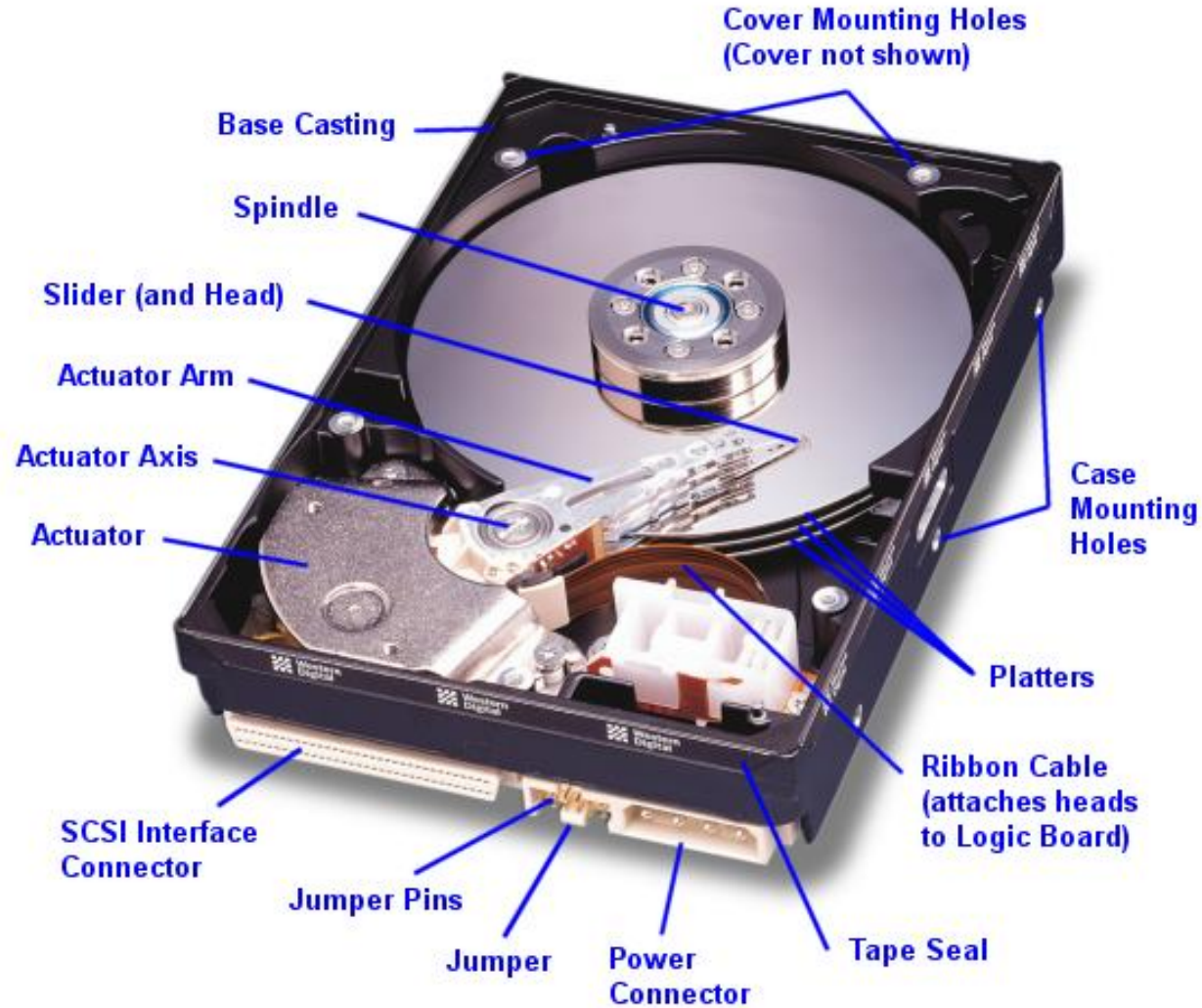

(<http://www.storagereview.com/guide2000/hdd/...>)

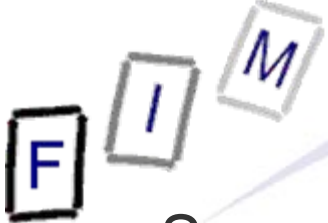

# General aspects of harddisks

- Several different sized exist
  - Typically named according to size of disks, not the case
    - » Note: They are not absolutely accurate (3,5" drive → 3,74" disk)!
- Rotating disks = " platters"
  - Made from aluminium or compounds; perhaps even glass
  - Coating: Ironoxide, Cobalt, ...
- "Comb" with read-/write heads
- Landing Zone / Auto Parking: Resting the head on the surface when not spinning in an area where there is no data
  - In olden times: Manual. Today fully automatic
- Impenetrable to dust, but not airtight
- " Geometry"
  - Number of platters, heads, cylinders, sectors
- Reserve tracks to enable size guarantee
  - Every disk has some physical errors!

# Tracks and sectors

- Formatting the disk creates a file system on the media
  - Which must be able to address individual "parts"!
- A disk is divided into (thousands) of concentric circles = tracks
- Each track is subdivided into sectors of each 512 bytes
  - Not every track has the same number of sectors, however!
- Sector = Smallest addressable unit
  - Larger units might be created on higher levels
    - » Example: Clusters, partitions, directories, files, ...

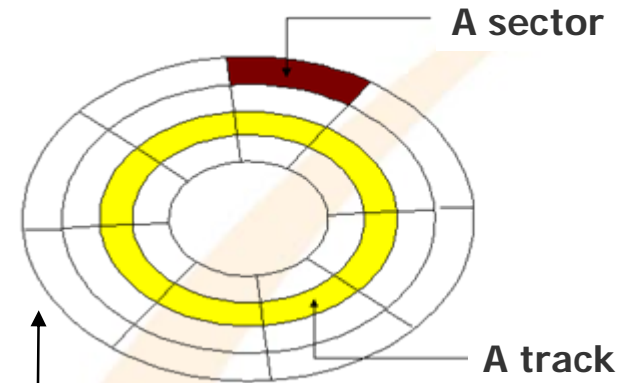

Track 0 = At the outside

One disk (upper surface!)

# Tracks and sectors

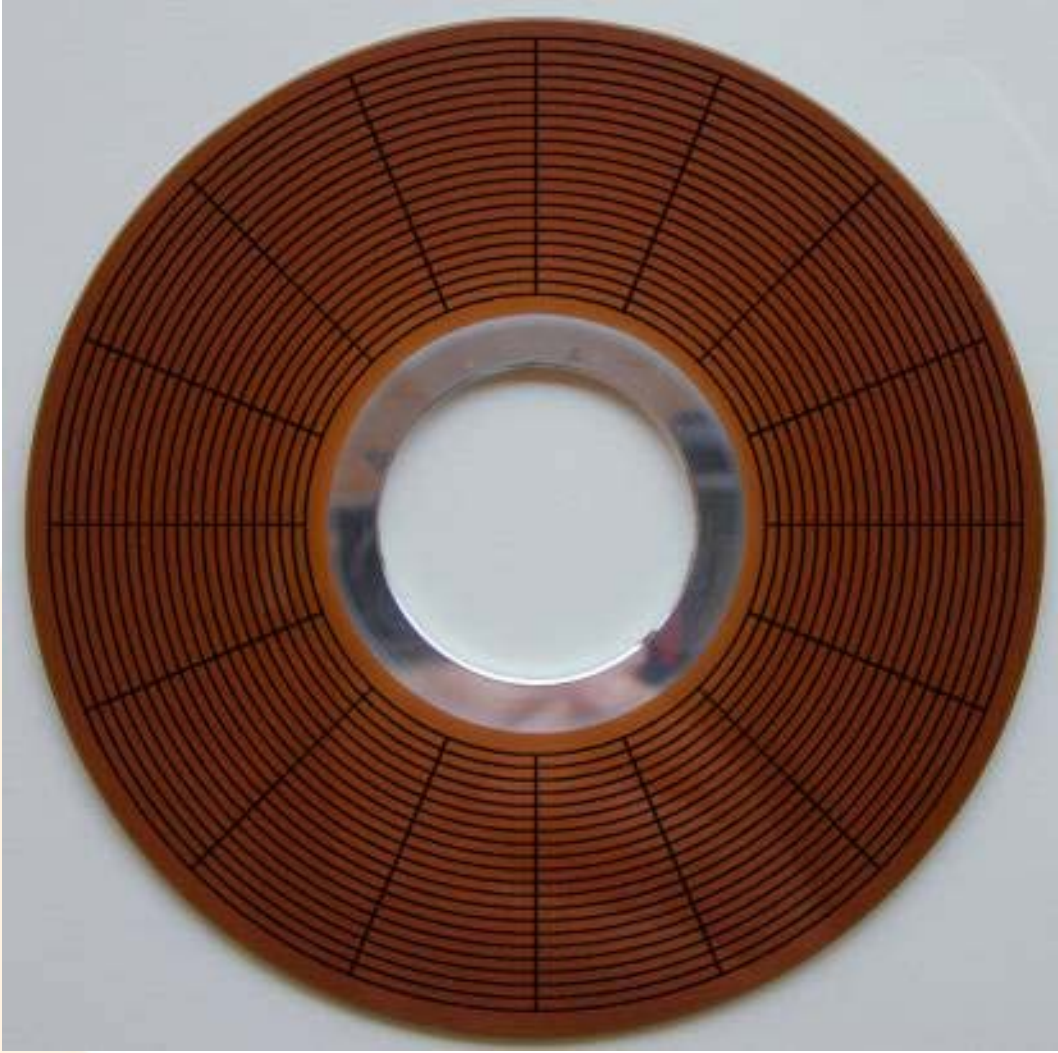

- 5,25" disk
  - 2 sides
  - á 40 tracks
  - á 9 sectors
  
- Space for data:
  - $2 * 40 * 9 * 512$
  - 368640 Bytes
  - » =360 kBytes

Image: 20 tracks, 16 sectors

Source: <http://www.storagereview.com/guide2000/ref/hdd/geom/tracks.html>

# Zoned Bit Recording

- Zones with different number of sectors per track
  - Why not different for each track? → Because, ...

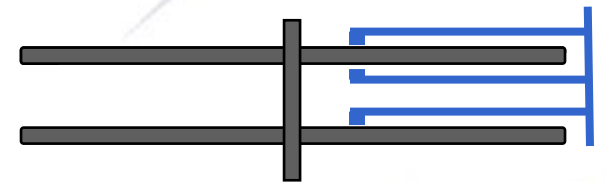
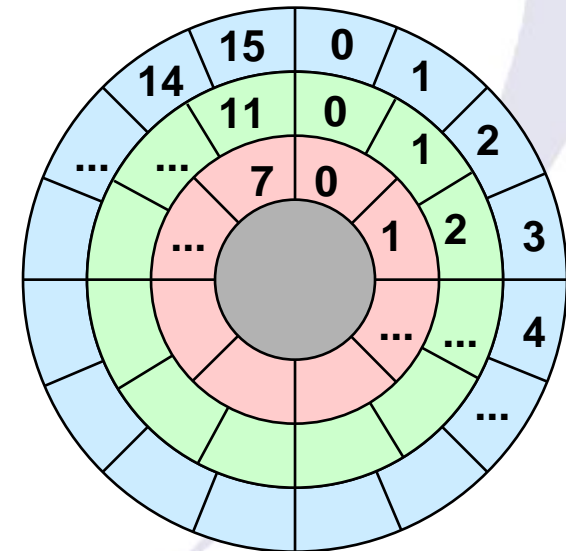
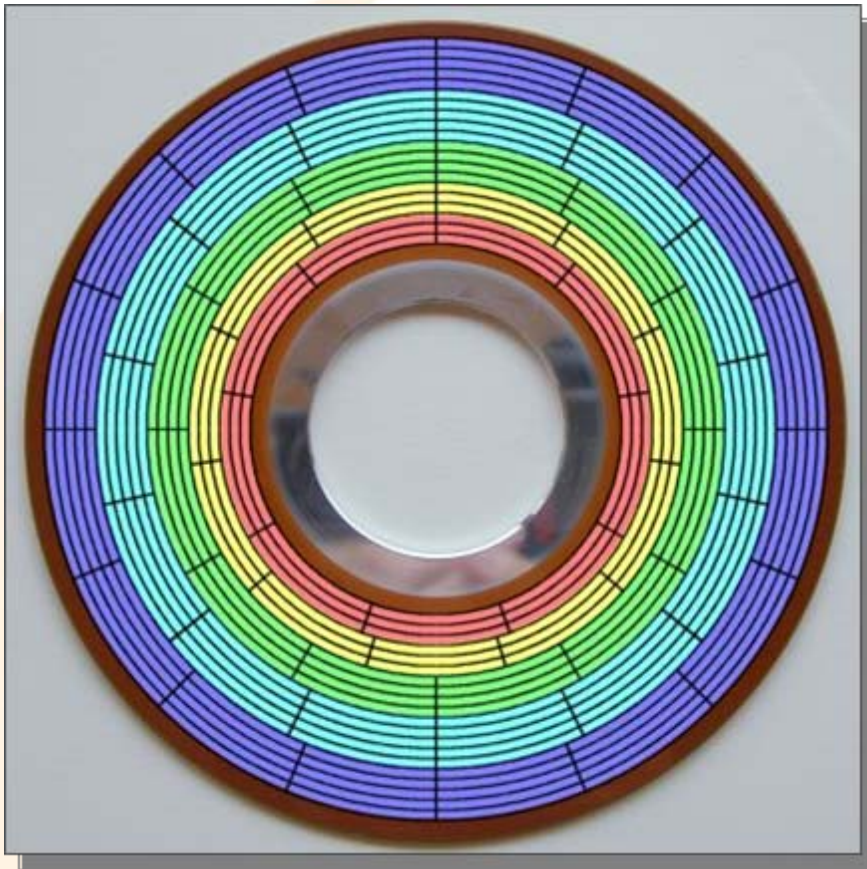

Source: <http://www.storagereview.com/guide2000/hdd/...>

- All tracks on a harddisk which are aligned
  - A harddisk may consist of several physical disks (=platters)
  - All physical disks spin at the same rate and synchronously (=common shaft)
- Accessing data on the same cylinder is possible without moving the heads!
  - All heads are mounted on a single actuator arm → Simultaneous moves
- Example: A cylinder of a harddisk with 4 platters consists of 8 tracks

*Tracks, Cylinders, and Sectors*

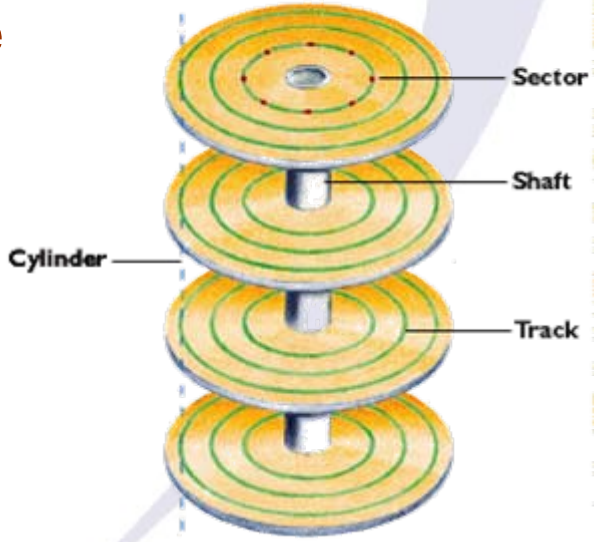



# Physical structure of platters

## Sector

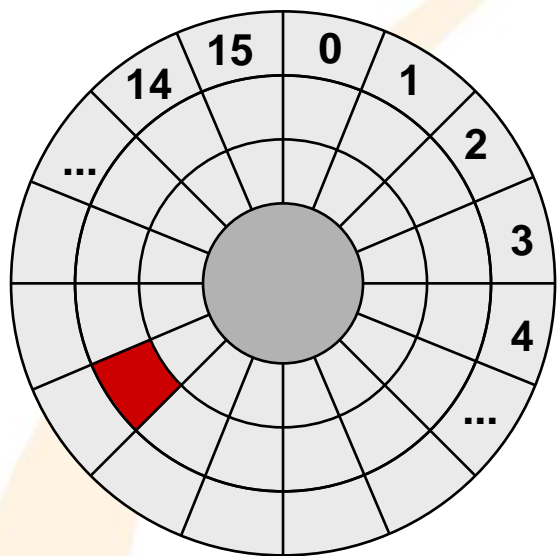

**sec\_per\_track**  
(16)

**sec**  
[0 .. sec\_per\_track-1]

## Track

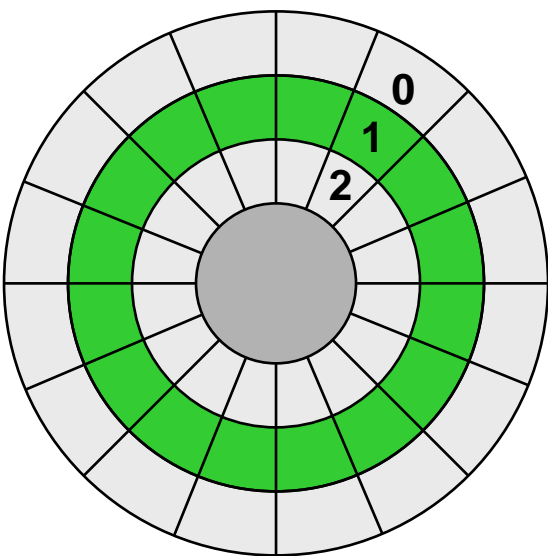

**nr\_cyl**  
(3)

**cyl**  
[0 .. nr\_cyl-1]

## Cylinder

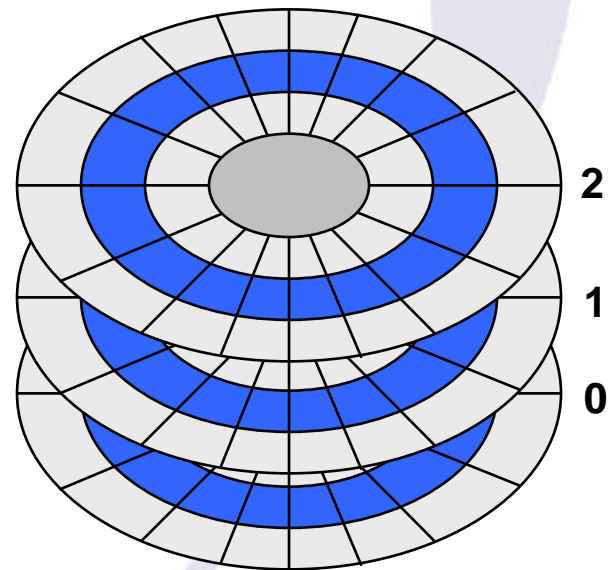

**tracks\_per\_cyl**  
= Number of heads  
(3)

**head**  
[0 .. tracks\_per\_cyl-1]



# Introducing "clusters"

- Several sectors are combined to a single cluster
- Cluster = Smallest part which can be addresses individually by the operating system
- Introduced to manage large/variable-size harddisks by OS
  - Example: FAT16 can only address  $2^{16}$  units
    - » 1 unit = 1 sector → 32 MB
    - » 1 unit = 1 cluster (=4 sectors each) → 128 MB
- What about fragmentation?
  - Internal fragmentation: Space between end of file and cluster
    - » Increases file slack → Forensic!!!
  - External fragmentation: Clusters not allocated in "sequence"
    - » Reduced slightly, as less "units" are needed for a single file
- Advantages and problems of cluster size?
  - A 1 byte file requires at least a full cluster (number of them?)
  - Larger disks possible



- BIOS

- „Basic Input / Output System“
- Provides also information on disks
- Cannot be changed by a program
  - » Modern computers: Flash-programmable, but often requires setting a jumper on the motherboard to enable this!

- MBR

- Master Boot Record
- Contains partition information on the disk and a small piece of code (initial loader for the operating system)
  - » This piece of code is executed first → Boot sector viruses!
- Contains the partition table
  - » List of partitions; which is active, set as boot, ...
- Located at Cylinder 0, head 0, sector 1 (harddisks, floppy disks)



Hardware

Reset

CPU starts executing the program at a pre-defined (hard-coded) address

Basic hardware initialisation

Selftest (POST)

Decision from where the system will boot

Floppy A:

Harddisk C:

CD-ROM D:

BIOS

# OS BOOT (2)

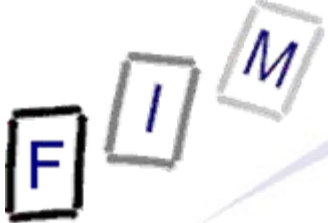

BIOS

MBR

PBR

OS

Load Master-Boot-Record and execute it

Select the *active partition*

Read Partition-Boot-Record and execute it

Execute OS-Loader

Start basic file system

Changes on disk **may** occur!

Changes on disk **will** occur!



- Boot sequence

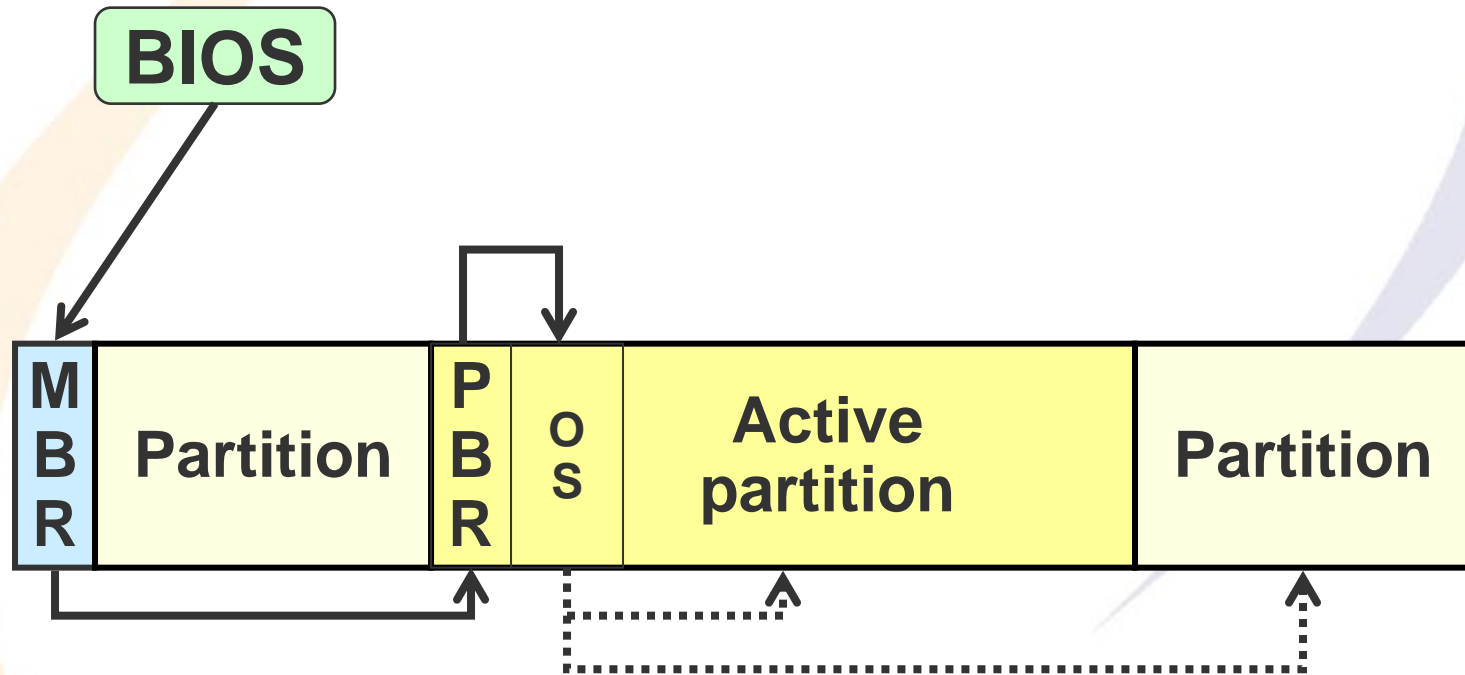



# The FAT file system

- Very old: Was developed by Microsoft for MS-DOS
  - Partially patented!
  - Little overhead
  - Used today still for memory sticks, flash drives, etc.
    - » Not used anymore for "main" OS partitions (NTFS, ext3, ...)
- Big advantage: Standardized
  - This means, available **fully** on various OS!
    - » NTFS can be used on Linux, but not completely
    - » Ext can be used on Windows, but not completely
- Various versions exist: FAT12, FAT16, FAT32
  - FAT16: Typically used on most flash disks etc.!
  - We will only discuss FAT16 here!
- Bad sectors are marked as such only within the cluster
- Simple and fast for smaller disks!

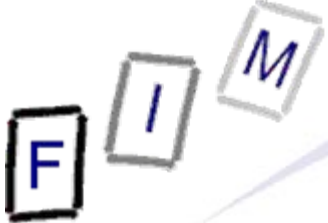

# Properties of FAT16

- Stores only short filenames: 8.3
  - Long filenames possible through a (patented) extension
- Stores creation, modification and access date
- Attributes: Read-only, hidden, system, archive
- Maximum number of files: 65517
  - FAT 12 →  $2^{12}$ , FAT 16 →  $2^{16}$ , FAT32 →  $2^{28}$
  - Root directory: Typically 512 files; maximum 32767 files
    - » Fixed maximum size; created during formatting
- Maximum file size: 2 GB
- Maximum volume size: 2 GB (theoretical: 4 GB)
- Allows hierarchical directories
  - Each counts against the limit as a file



# Physical layout of FAT16



Optional: Reserved sectors

- Boot sector: A single sector containing the boot code and the partition table
  - More reserved sectors immediately afterwards possible
- FAT1: The File Allocation Table
  - Contains the map to the data area (which clusters used)
- FAT2: Copy of FAT1
- Root directory (fixed location!)
  - Location and properties of files
    - » Note: Subdirectories are located in the data area!
- Data area: Where files and subdirectories are located



# The File Allocation Table (FAT16)

- Basic concept of storing/accessing a file:
  1. Locate file description in root directory
  2. Extract from description number of first cluster
  3. Read cluster
  4. Lookup this cluster number in FAT
  5. According to value found, go to step 3 (next cluster) or terminate (last cluster)
    - » Note: FAT-lookup can also be done in a single step for a whole file and cached until all data sectors were read!
- Each cluster is described in the FAT by a number as
  - Unused
  - Used by a file
  - Last cluster in a file
  - Bad cluster

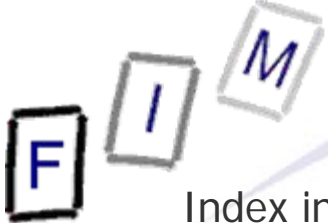

# The File Allocation Table (FAT16)

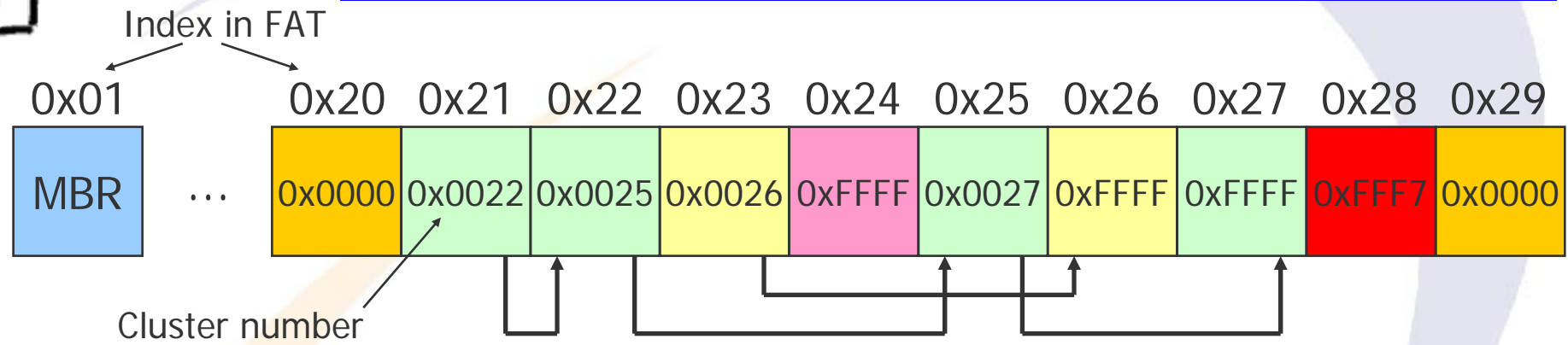

- The example contains 3 files
- Directory entries:
  - A: Start cluster 0x21
  - B: Start cluster 0x23
  - C: Start cluster 0x24
- Cluster 0x28 is erroneous
- Cluster 0x20 and 0x29 are free

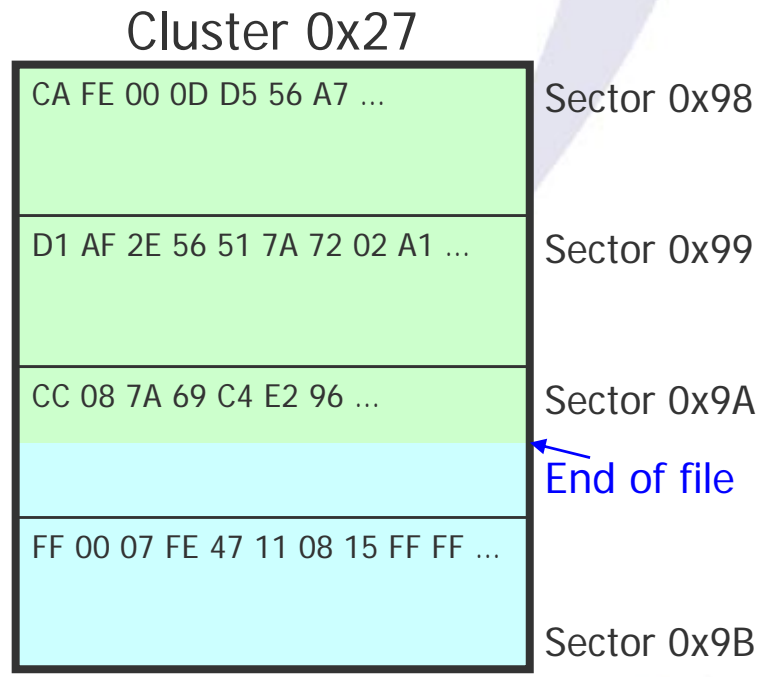



# Storing a directory in FAT16

- Like normal file, but format identical to root directory
  - 11 bytes: Name (8.3)
  - 1 byte: Attributes (Read-only, hidden, system, ...)
  - 5 bytes: Creation time and date
  - 2 bytes: Last access date (no time!)
  - 4 bytes: Last modification time and date
  - 2 bytes: First cluster number
  - 4 bytes: File size in bytes
  - 3 bytes: Reserved
- Deleting files:
  - Marked as deleted within the directory
  - Marking is done by setting first filename byte to "0xE5"
    - » The rest of the directory entry remains until reused!
  - In the FAT the entries are marked as "empty"

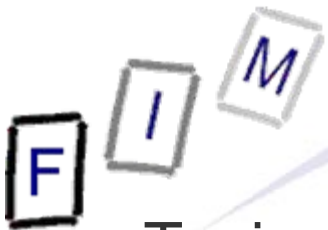

# FAT 16 and computer forensic

- Typically, files are not actually overwritten (see above)
  - Unless the physical area is reused, it is recoverable
    - » If it is not fragmented ... (we only have the first cluster number!)
  - Fragments of FAT chains may exist even then
    - » Partial recovery of files might be possible
- There is no "partition" slack **within** FAT
  - All clusters are used; there are no partitions within
- Slack typically does exist
  - Files are usually written only up to the end of the data
  - File Slack:
    - » Data is retained from previous content in the remaining sectors of the cluster; these are not written to
  - RAM slack:
    - » Data in the last sector of the file after its end will usually be random data from in-memory buffer; written to disk
      - Modern operating systems: Buffer is zeroed before use!

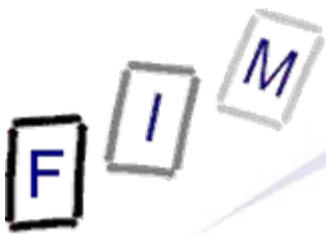

# The NTFS file system

- Internals are trade secrets of its creator Microsoft
  - But commercial licensing is possible
- There are no predefined attributes for files
  - Everything is stored as "Metadata", including filename, creation date, access permissions, ...
  - This allows easy extension to other associated data
- Names are stored as 16 Bit/character → UTF-16 possible
  - But not restricted to it, any 16-Bit values are allowed
- Organisation is in a B-Tree
  - Allows very fast searching for huge numbers of elements
    - » Drawback: Complex to implement
- Journaling is built-in
  - However, only for the file system itself, not the data
    - » The directory will be correct, but the file may be garbled!

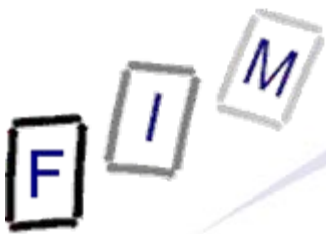

# Properties of NTFS

- Some file names are not allowed
  - Reserved for internal management; all start with "\$"
    - » Examples: \$MFT, \$MFTMirr (Master File Table & its mirror)
- Maximum volume size:
  - $2^{32}-1$  clusters (implemented);  $2^{64}-1$  clusters (theoretical)
  - With 4 kB cluster size → 16 TB
  - Note: Boot partition was typically limited to 4 GB as it was initially FAT16 (and converted to NTFS later; <=NT only )!
- Maximum file size:
  - $\approx 16$  TB (implemented);  $\approx 16$  EB ( $2^{64}-2^{10}$  B; theoretical)
- Compared to FAT there is no date restriction
  - Range from 1.1.1601 – 28.5.60056
- Suffers from potential defragmentation problems
  - The defragmentation API only allows relocating 16 clusters at once and only every 16 clusters of a file

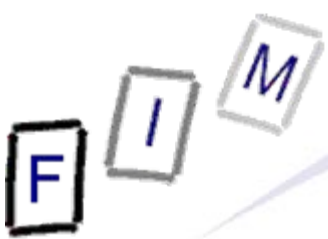

# Master File Table (MFT)

- Contains the "directory" structure and the files
  - Located at the beginning of the disk in a reserved space
  - If it grows too much, it is extended to the data area
- Contains file records of fixed size
  - These are reused after deletion
  - A reserved area for system files exists
- File records:
  - Each file has at least one with the "standard" attributes
  - More space needed? → More records allocated to file
  - Contains e.g. information on access rights
- Updates are first logged, then performed, then marked as completed in the log → Journaling



# Alternate Date Streams (ADS)

- Additional "attributes" of a file: This can be a file itself!
- Attention: In the "normal" UI these are invisible!
  - The file shows up identically in the GUI
  - The file shows up identically on the command line
    - » Note: The file size stays the same!
  - The file behaves exactly as it did before
  - They show only up in the taskmanager in recent versions
  - What changes is the modification timestamp
- Alternate Data Streams cannot be disabled or limited
  - Only "normal" access restrictions of the base file apply
  - But copying the base file to a system without ADS will automatically strip them
    - » After a warning message!
- Windows 7: Mostly impossible through the GUI/CMD-line
  - Still exist & can be read etc. through API!

# ADS example: Win XP



```
C:\ Command Prompt
C:\temp\ADS-Example>dir
Volume in drive C is Local Disk
Volume Serial Number is 28A3-D19E

Directory of C:\temp\ADS-Example

27.07.2007  11:11    <DIR>          .
27.07.2007  11:11    <DIR>          ..
23.08.2001  14:00                114.688 calc.exe
04.01.2007  04:10                61.952 lads.exe
04.08.2004  00:56                69.120 notepad.exe
           3 File(s)                245.760 bytes
           2 Dir(s)          9.593.368.576 bytes free

C:\temp\ADS-Example>type calc.exe >notepad.exe:calc.exe

C:\temp\ADS-Example>dir
Volume in drive C is Local Disk
Volume Serial Number is 28A3-D19E

Directory of C:\temp\ADS-Example

27.07.2007  11:11    <DIR>          .
27.07.2007  11:11    <DIR>          ..
23.08.2001  14:00                114.688 calc.exe
04.01.2007  04:10                61.952 lads.exe
27.07.2007  11:11                69.120 notepad.exe
           3 File(s)                245.760 bytes
           2 Dir(s)          9.593.253.888 bytes free

C:\temp\ADS-Example>start c:\temp\ADS-Example\notepad.exe:calc.exe

C:\temp\ADS-Example>
```

Taskmanager:

msmpng.exe	00
mysqld-nt.exe	00
notepad.exe:calc.exe	00
OWSTIMER.EXE	00

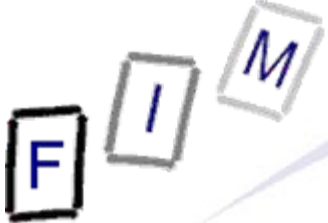

Free space would normally change: But these files are so small that the complete data is stored within the MFT  
→ Not even a single sector is lost!

Windows 7:  
Parameter "/R" displays ADS

"lads"-Tool works as before

```

C:\Windows\system32\cmd.exe
C:\temp\ADS-Example>dir
Volume in drive C has no label.
Volume Serial Number is D009-4243

Directory of C:\temp\ADS-Example

19.04.2010  15:51    <DIR>          .
19.04.2010  15:51    <DIR>          ..
04.01.2007  04:10             61.952 lads.exe
19.04.2010  15:51             16 Test.txt
                2 File(s)      61.968 bytes
                2 Dir(s)   108.681.781.248 bytes free

C:\temp\ADS-Example>echo "Secret Data" >Test.txt:Hidden.txt

C:\temp\ADS-Example>dir
Volume in drive C has no label.
Volume Serial Number is D009-4243

Directory of C:\temp\ADS-Example

19.04.2010  15:51    <DIR>          .
19.04.2010  15:51    <DIR>          ..
04.01.2007  04:10             61.952 lads.exe
19.04.2010  15:52             16 Test.txt
                2 File(s)      61.968 bytes
                2 Dir(s)   108.681.781.248 bytes free

C:\temp\ADS-Example>more < Test.txt:Hidden.txt
"Secret Data"

C:\temp\ADS-Example>dir/r
Volume in drive C has no label.
Volume Serial Number is D009-4243

Directory of C:\temp\ADS-Example

19.04.2010  15:51    <DIR>          .
19.04.2010  15:51    <DIR>          ..
04.01.2007  04:10             61.952 lads.exe
19.04.2010  15:52             16 Test.txt
                16 Test.txt:Hidden.txt:$DATA
                2 File(s)      61.968 bytes
                2 Dir(s)   108.681.781.248 bytes free

C:\temp\ADS-Example>lads

LADS - Freeware version 4.10
(C) Copyright 1998-2007 Frank Heyne Software (http://www.heysoft.de)
This program lists files with alternate data streams (ADS)
Use LADS on your own risk!

Scanning directory C:\temp\ADS-Example\

  size  ADS in file
-----
    16  C:\temp\ADS-Example\Test.txt:Hidden.txt

    16 bytes in 1 ADS listed

C:\temp\ADS-Example>

```

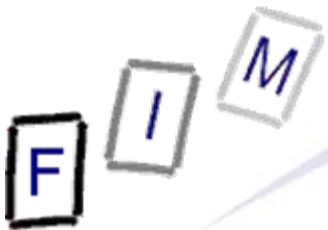

- NTFS contains access permissions
  - Without the correct permission, no access is possible
    - » Use direct (hex) access to the disk
  - Alternative: Insert (copy of) disk into system where you are the administrator (same SID on every system!)
    - » Reason: The administrator can reset permissions!
      - These are then lost (→ copy!), but you get access to the file
- NTFS supports file encryption
  - Specifically targeted at making the disk "unreadable" by third persons (typically thieves, but includes CF!)
  - Files are encrypted separately, i.e. only their content
  - The key is stored for each user and with "recovery agents"
    - » Typically the administrator
    - » Newer versions require admin rights and the users password!
  - Tools can decrypt, but  $\geq$  XP SP1 the recovery agent's password is needed

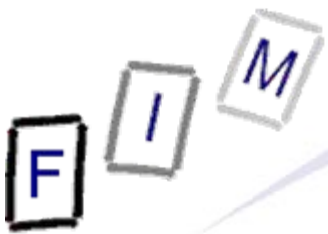

# NTFS and computer forensic

- General considerations like File-/RAM-slack apply as well
- NTFS supports "Volume Shadow Copies!"
  - Intended for backups of open files
  - Keeps "old" versions of files
  - When the file is written to, the previous values are copied to another place; on reading it is "overlaid" back
  - These shadow copies **reside on the disk** and can therefore contain **copies of older version/deleted files!**
- Special software needed for interpretation
  - As no specification is freely available and the structure is complex in itself
- Bitlocker (Vista) may require live gathering!
  - May be configured so it asks for password before boot!
    - » **Whole disk is encrypted, i.e. no NTFS structures readable**

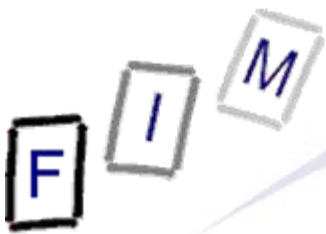

# The EXT3 file system

- EXT3 is EXT2 + enhancements
  - This means, the EXT2 tools also work on EXT3!
  - Added:
    - » Journal: For crash-resistance
    - » Tree-based directory indices: For very large directories
    - » Online file system growth: Enlarging "on the fly"
- EXT3 is based on "inodes" (and blocks=clusters)
  - Contains metadata (file size, dates, ...)
    - » But not: Filename (→ in directory)!
  - Links to the actual data blocks
    - » These may be direct or (1-N) levels of indirection
      - Indirection: Pointer to block containing pointers to data blocks
      - EXT3: 12 direct, 1 single indirect, 1 double indirect, 1 triple indirect
  - Reference counter (for links)

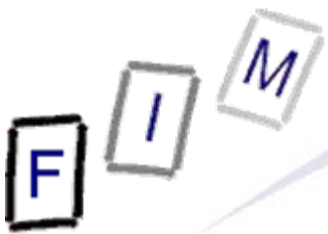

# Properties of EXT3

- Maximum volume size: 16 TB (4 kB block size)
- Maximum file size: 2 TB (4 kB block size)
- Maximum filename size: 255 Bytes
  - May contain all characters except 0x00 and '/'
- Stores modification, attribute mod., and access time
- No real defragmentation or online compression
- An EXT3 partition is subdivided into block groups
  - Block count per block group is variable
  - Determined on formatting
- "Clusters" are called "blocks" in EXT3
  - The block size is determined on formatting: Typ. 4 kB

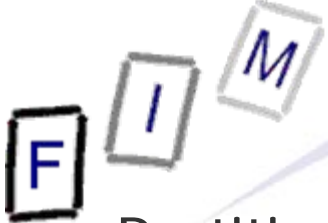

# EXT3 physical layout

Partition:

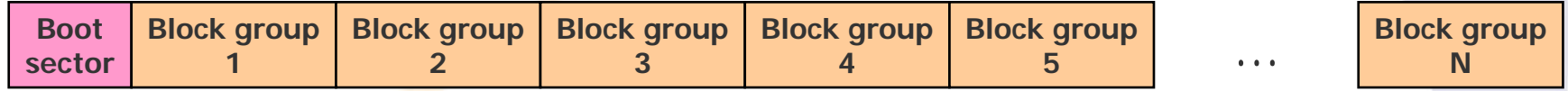

Single block group:

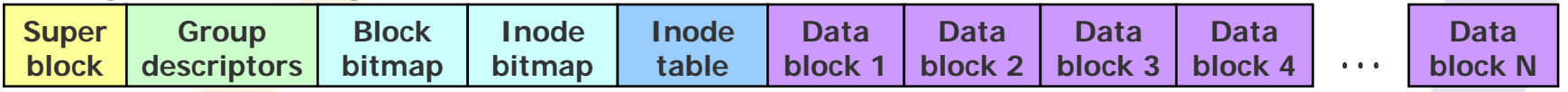

- Each block group contains redundant copy of general information structures (superblock + FS descriptor)
  - Block+Inode bitmap, Inode table: **Only** for **this** block group!
  - Block groups reduce the distance between file information and file data
    - » This is not a hard allocation: Data from a file can also be in a different block group!
  - "Sparse superblocks": Repeated only in some groups to reduce space used on large volumes



# Block and Inode bitmaps

- Block bitmap: Which blocks are used/free
  - Every block is represented by a single bit (→ bitmap)
  - Organization:
    - » 1 = used, 0 = free
    - » Block 1 = Byte 0 Bit 0, Block 2 = Byte 0 Bit 1,  
Block 8 = Byte 0 Bit 7, Block 9 = Byte 1 Bit 0
- Inode bitmap:
  - Every Inode is represented by a single bit
  - Organization: Like block bitmap
    - » The first bits are always set: Superblock, group desc., ...!



# Inodes

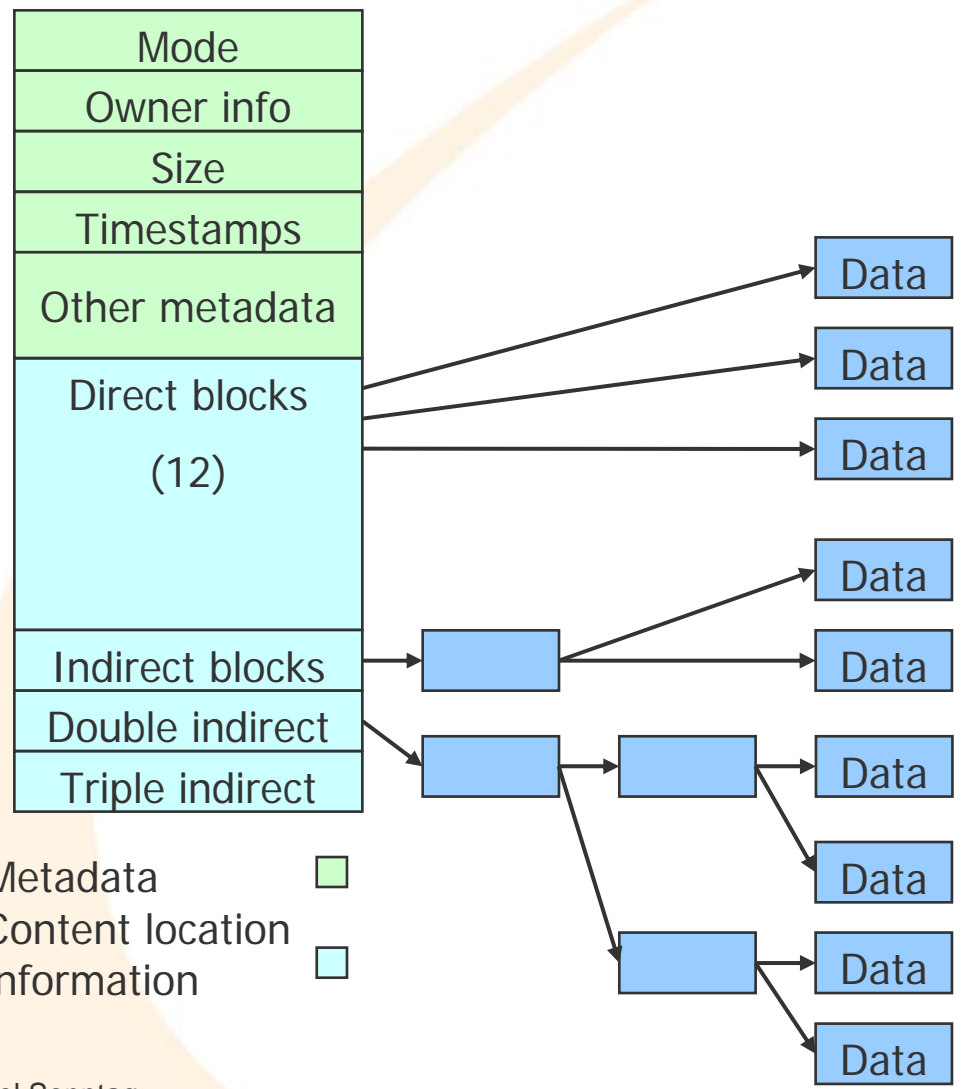

- Mode: Permissions
  - Includes Inode type
    - » File/Directory/Link/...
- Owner info:
  - User and group ID
- Size: File size in Bytes
- Timestamps:
  - Access time
  - Creation time
  - Modification time
  - Deletion time
- Other metadata:
  - Link/Block count
  - File flags
  - ...

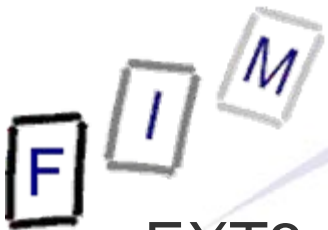

- EXT3 undelete is very difficult
  - File size and block addresses are overwritten on delete!
    - » Reason: Easier recreation through journal after crash
    - » Result: File name still exists, file data still exists, but which blocks of data belong to the file in which order is lost
  - Undelete is still possible, but it must work on the level of individual blocks/clusters, not just "unmarking the directory entry as deleted"!
    - » Basis: Journal entries or "file carving"!
    - » Journal: Several inodes/block; Whole block is saved in journal
      - Journal entries for other files may contain "old" version of the deleted inode and therefore the block pointers!
        - Note: Requires also the indirect blocks to still exist for large files!
    - » Carving: Try to detect start/end of file by "magic numbers"
      - Note: This approach identify only parts of the file. The rest must be assumed to be "physically in between"!
      - This fails when the file is fragmented → Undelete **very** difficult!



# EXT3 directory

- Directories are "ordinary" files
  - Root directory: Inode number is part of superblock!
  - They contain no metadata at all → Inode
- Format is very simple:
  - → Inode associated with file (4 Bytes)
  - → Length of this entry in bytes (2 Bytes)
  - → Filename length in bytes (1 Byte)
  - → File type (1 = file, 2 = directory, 7 = Symlink, ...; 1 Byte)
  - → Filename (N Bytes)

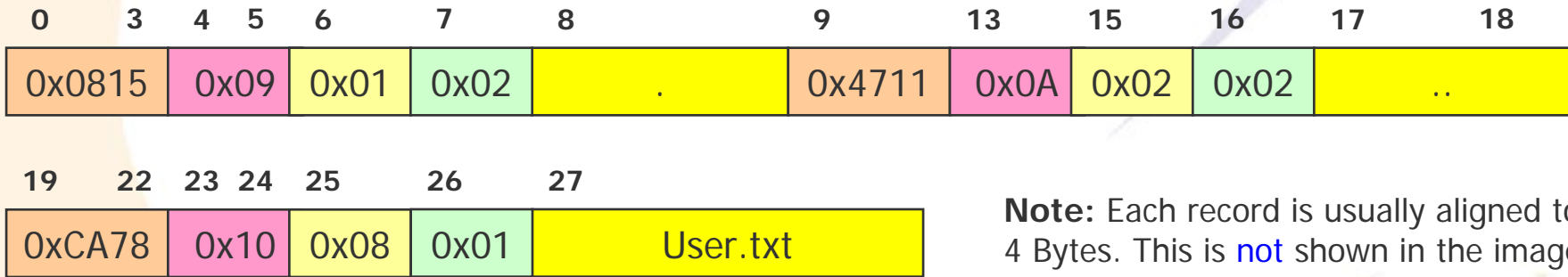

**Note:** Each record is usually aligned to 4 Bytes. This is **not** shown in the image!



- The traditional unix rights system:
  - There are users and groups
  - Each user is member of a single primary and an arbitrary number of secondary groups
  - One special user („root“), has all rights on (normal) files or can obtain them through changing ownership/rights
  - Each file has an owner and an "owning group"
  - There are only 3 permissions: "read", "write", and "execute"
  - A combination of these three permissions can be set for three different groups of persons:  
The owner, the owning group, and for everyone
  - Additionally there are a few specialty bits
    - » E.g. executing the program as owner/owning group, regardless of the actual user

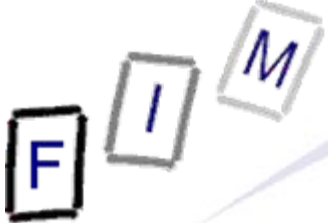

# EXT3 security example

Command: `ls -al`

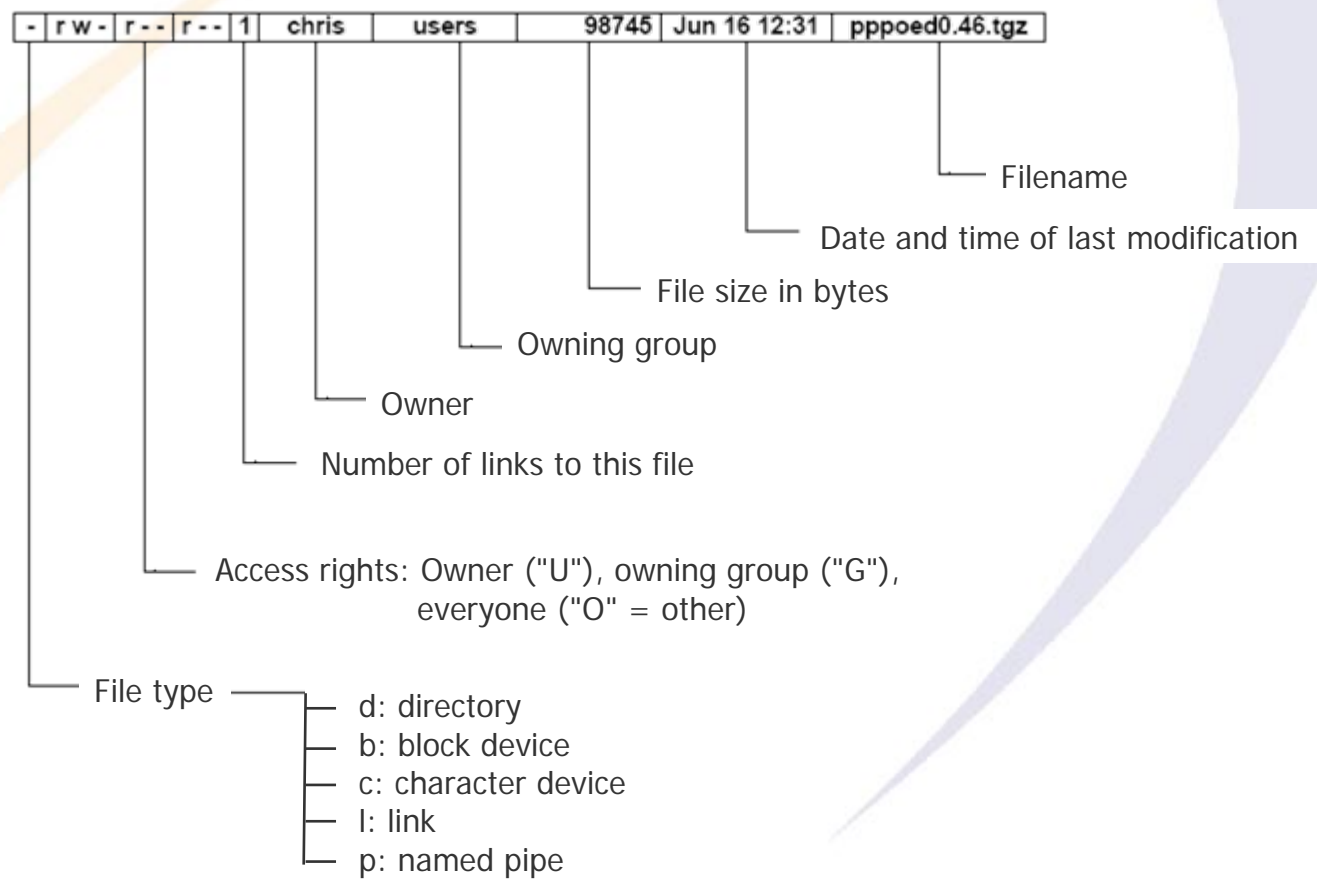

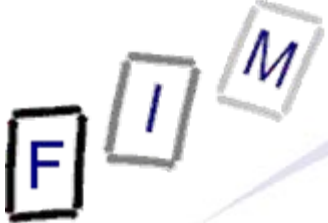

# Access control lists

- ACLs also exist, but on a different layer
  - Supported by: Ext2, Ext3, XFS, JFS, ReiserFS
- The normal permissions (rwx) of a file can be assigned to arbitrary additional other users and groups
  - Commands: getfacl, setfacl
- Example:
  - "getfacl index.html"
  - # file: index.html
  - # owner: root
  - # group: apache
  - user::rw-
  - user:sonntag:rwx
  - group::r--
  - other::---

Attention:  
File system must be mounted accordingly for this to be supported (/etc/fstab !)

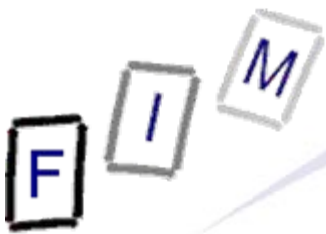

# EXT3 and computer forensics

- EXT3 is a journaling file system
  - Depending on the mode used, file metadata and perhaps even file data may be present in the Journal!
    - » This is actually a problem for wiping too ...
  - Making a copy of a live system is difficult
    - » Special tools needed or remounting as read-only!
- Recovering deleted files can be very difficult
- General consideration like File-/RAM-slack apply as well
  - But swap space is a separate partition, not a file, and therefore itself a "file system"

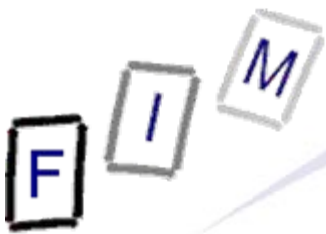

- Recreating evidence from a file system requires intimate knowledge of the file system or special tools
  - An important approach is "file carving", i.e. recreating files through assembling only data sectors and ignoring all directory entries
    - » This is much more independent of the file system, but also more difficult; e.g. which sectors belong to a binary file
      - Plain text files → Easy!
  - Many different file systems exist, but only few are common
    - » "Rare" file systems might pose special difficulties!
- Journaling file systems offer an additional approach
  - Some data might be present in the journal
    - » E.g. recently deleted data

F I M

# Questions?

Thank you for your attention!

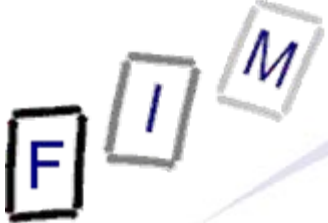

- Alternate data stream  
[http://www.wikistc.org/wiki/Alternate\\_data\\_streams](http://www.wikistc.org/wiki/Alternate_data_streams)
- Berghel, H., Brajkovska: Wading into Alternate Data Streams. Communications of the ACM April 2004/Vol. 47, No. 4, 21-27 [http://portal.acm.org/ft\\_gateway.cfm?id=975836&type=pdf&coll=GUIDE&dl=ACM](http://portal.acm.org/ft_gateway.cfm?id=975836&type=pdf&coll=GUIDE&dl=ACM)